

## Formimidoyl Cyanide and Isocyanide from Azidoacetonitrile by Photolysis

By Joseph H. Boyer,\* Jonathan Dunn, and Johannes Kooi, Chemistry Department, University of Illinois, Chicago Circle Campus, Chicago, Illinois 60680, U.S.A.

Photoelimination of nitrogen from azidoacetonitrile (1) produced formimidoyl cyanide (2). At  $-196^{\circ}\text{C}$  further irradiation transformed the cyanide (2) into formimidoyl isocyanide (3); both (2) and (3), detected by i.r. absorption, can be intermediates in the formation of hydrogen cyanide and adenine (4) from a solution of (1) irradiated at  $25\text{--}40^{\circ}\text{C}$ . Photodissociation of *N*-ethyl- (5a), *N*-isopropyl- (5b), and *N*-*t*-butyl-formimidoyl cyanide (5c) gave the corresponding *N*-alkyl isocyanide (7a—c) (3%) at  $25\text{--}40^{\circ}\text{C}$  and in detectable amounts at  $-196^{\circ}\text{C}$ . Azidoacetonitrile (1) at  $125^{\circ}\text{C}$  dimerised to give 5*H*,10*H*-ditetrazolo[1,5-*a*:1',5'-*d*]pyrazine(15).

A MAJOR role in prebiotic chemical evolution has been attributed to monomeric hydrogen cyanide.<sup>1,2</sup> By

<sup>1</sup> J. P. Ferris, D. B. Donner, and A. P. Lobo, *J. Mol. Biol.*, 1973, **74**, 511.

implication this role is shared with the simple oligomeric forms although the process of oligomerisation is not well

<sup>2</sup> R. A. Sanchez, J. P. Ferris, and L. E. Orgel, *J. Mol. Biol.*, 1967, **30**, 223.

understood and the simplest oligomer, an undetected dimer, may be unknown. Formimidoyl cyanide (2), often selected as a likely candidate for the unknown dimer,<sup>3-5</sup> has now been produced for the first time by photoelimination of nitrogen from azidoacetonitrile (1).

Elimination of nitrogen at  $-196^{\circ}\text{C}$  from the azide (1) irradiated at 254 nm was slow, but proceeded at a convenient rate with irradiation from a 450 W Hanovia lamp with a Vycor filter. After 20 min new i.r. absorption appeared at 3 250s (NH), 3 155s (CH), and 1 605m  $\text{cm}^{-1}$  (C=N), assigned to formimidoyl cyanide (2). Absorption characteristic of both the cyanide (2) and formimidoyl isocyanide (3) was seen after 80 min, but after 9 h of irradiation at  $-196^{\circ}\text{C}$  absorption characteristic of (1) and (2) had disappeared and bands at 3 250s (NH), 3 135s (CH), 2 101s ( $-\dot{\text{N}}=\bar{\text{C}}$ ), and 1 618  $\text{cm}^{-1}$  (C=N), attributed to formimidoyl isocyanide (3),<sup>6,7</sup> remained. Irradiation for 5 h more brought no further change. Since hydrogen cyanide was not detected by i.r. absorption<sup>8</sup> (near 3 250, 2 090, 1 450, and 770–710  $\text{cm}^{-1}$ ; see Experimental section), it was assumed either that the photodissociation of (2) and (3) at  $-196^{\circ}\text{C}$  did not occur, or that it did so reversibly. (Absorption at 3 620, 2 020, and 477  $\text{cm}^{-1}$  was observed<sup>9</sup> for hydrogen isocyanide in an argon matrix at  $-259^{\circ}\text{C}$  but disappeared on warming to  $-238^{\circ}\text{C}$  as isomerisation occurred.) The dissociation of azidoacetonitrile under electron bombardment into nitrogen and hydrogen cyanide is revealed in strong peaks at  $m/e$  28 and 27; however, formimidoyl cyanide (or isocyanide) is barely detectable ( $m/e$  54) at both 70 and 20 eV.

At 25–40  $^{\circ}\text{C}$  irradiation at 254 or 300 nm slowly released nitrogen from the azide (1) in cyclohexane or in methylene chloride as hydrogen cyanide and adenine (4) were formed. Hydrogen cyanide was identified by its odour and i.r. absorption. Adenine, a known pentamer of hydrogen cyanide,<sup>1</sup> was detected in the brown amorphous solid product by direct comparison with an authentic sample in mass spectrometric and paper chromatographic analysis, and by g.l.c. analysis of the trimethylsilyl derivative obtained from both authentic adenine and the crude product mixture. Relative to the mass spectrum for authentic adenine, enrichment at  $m/e$  108 and 81 can be attributed to the presence of a tetramer<sup>10</sup> of hydrogen cyanide in the product mixture.

Irradiation at 300 nm and 25–40  $^{\circ}\text{C}$  produced a slight increase in the *anti-syn*<sup>11</sup> ratio of both *N*-ethyl- (5a) and

*N*-isopropyl-formimidoyl cyanide (5b), but no isomerisation of (5a), (5b), or *N*-*t*-butylformimidoyl cyanide (5c) into an *N*-alkylformimidoyl isocyanide (6a–c) was detected (this isomerisation at  $-196^{\circ}\text{C}$  was reported in

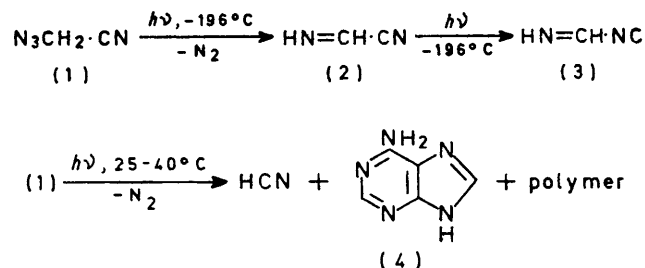

error<sup>12</sup>). Photodissociation of (5a) and (5b) in 90 h and of (5c) in 250 h gave ethyl (7a) (2%), isopropyl (7b) (3%), and *t*-butyl isocyanide (7c) (3%), some polymer, and unchanged imidoyl cyanide (54, 83, and 74%, respectively). Attempts to produce a formimidoyl cyanide (5) or isocyanide (6) by combining an alkyl isocyanide (7) with hydrogen cyanide in an uncatalysed photoreaction, and attempts to prepare a formimidoyl isocyanide (6) by treating a formimidoyl cyanide (5) with silver cyanide were unsuccessful.

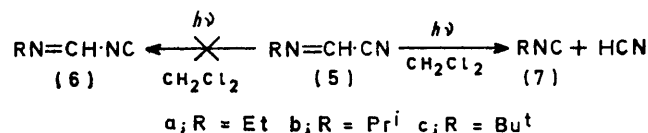

The isomerisation (2)  $\rightarrow$  (3) may be the first observed direct rearrangement of a *C*-cyano- into a *C*-isocyano-group. Similar *Si*-cyano *e.g.*  $\text{Me}_3\text{Si}\cdot\text{NC} \rightleftharpoons \text{Me}_3\text{Si}\cdot\text{CN}$ ,<sup>13a</sup> or *O*-cyano, *e.g.*  $\dot{\text{O}}\cdot\text{NC} \rightleftharpoons \dot{\text{O}}\cdot\text{CN}$ ,<sup>13b</sup> rearrangements are known. The formation of an isocyanide by  $\gamma$ -irradiation of methacrylonitrile has been claimed;<sup>13c</sup> however, the product, which showed i.r. absorption at 2 090  $\text{cm}^{-1}$ , may have been hydrogen cyanide (see above; vinyl isocyanides absorb between 2 122 and 2 132  $\text{cm}^{-1}$ ).<sup>7,14</sup> The occurrence of photoisomerisation of *o*-cyanophenol into *o*-isocyanophenol has been suggested,<sup>15</sup> and a similar rearrangement of diaminomaleonitrile (8) (a known tetramer of hydrogen cyanide) into a monoisocyanide (9) was considered along with a rearrangement of an iminoazetinone (10) to account for the formation of 4-amino-5-cyanoimidazole

<sup>12</sup> J. Dunn and J. H. Boyer, 'Iminoacetonitrile from Azidoacetonitrile,' Abstracts of papers ORGN 108, American Chemical Society National Annual Meeting, Chicago, August 1973.

<sup>13</sup> (a) M. R. Booth and S. G. Frankiss, *Chem. Comm.*, 1968, 1347; M. Dakkouri and H. Oberhammer, *Z. Naturforsch.*, 1974, 1974, 29a, 513; (b) F. J. Holsboer and W. Beck, *Chem. Comm.*, 1970, 262; (c) M. Talat-Erben, E. Uenseren, and N. Seber, AEC Accession No. 46326, Report No. CNAEM-28, 1965 (*Chem. Abs.*, 1966, 65, 6565f; *Nucl. Sci. Abs.*, 1965, 19, 46326).

<sup>14</sup> D. S. Matteson and R. A. Bailey, *J. Amer. Chem. Soc.*, 1968, 90, 3761.

<sup>15</sup> J. P. Ferris, F. R. Antonucci, and R. W. Trimmer, *J. Amer. Chem. Soc.*, 1973, 95, 919; J. P. Ferris and F. R. Antonucci, *ibid.*, 1974, 96, 2014.

<sup>3</sup> J. H. Boyer and H. Dabek, *Chem. Comm.*, 1970, 1204.

<sup>4</sup> J. P. Ferris, D. B. Donner, and W. Lotz, *J. Amer. Chem. Soc.*, 1972, 94, 6968.

<sup>5</sup> Th. Völker, *Angew. Chem.*, 1957, 69, 728.

<sup>6</sup> (a) M. Avram and Gh. Mateescu, 'Infrared Spectroscopy, Wiley-Interscience, New York, 1972, p. 471.

<sup>7</sup> R. W. Stephany, M. J. A. de Bie, and W. Drenth, *Org. Magnetic Resonance*, 1974, 6, 45.

<sup>8</sup> Ref. 6, p. 452.

<sup>9</sup> D. E. Milligan and M. E. Jacox, *J. Chem. Phys.*, 1963, 39, 712; 1967, 47, 278.

<sup>10</sup> O. W. Webster, D. R. Hartter, R. W. Begland, W. A. Sheppard, and A. Cairncross, *J. Org. Chem.*, 1972, 37, 4133.

<sup>11</sup> J. H. Boyer and J. Kooi, unpublished results.

(11).<sup>16</sup> The latter has been challenged<sup>17</sup> and supported.<sup>18</sup>

The isomerisation (2)  $\rightarrow$  (3) can be accounted for *a priori* by either a concerted intermolecular transfer of a

and trimerisation<sup>22</sup> of the latter into the formamidine (14), followed by elimination<sup>22</sup> of hydrogen cyanide. Indirect support for the trimerisation was noted in a similar reaction for benzoyl isocyanide.<sup>22</sup>

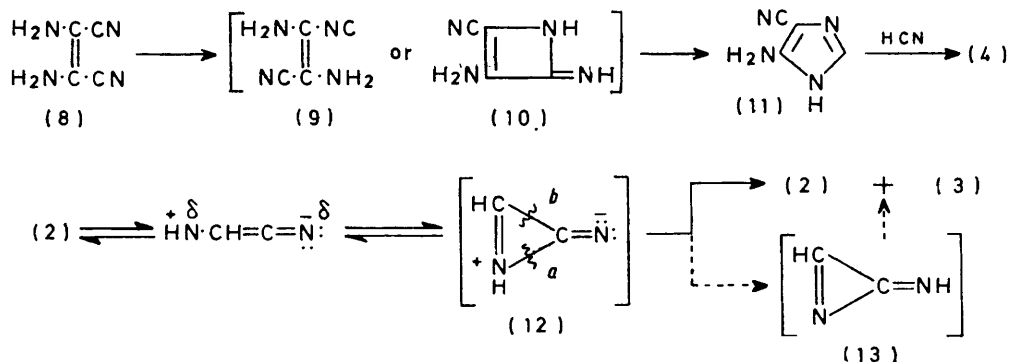

cyano- as an isocyano-group or a dissociation of (2) into formimidoyl and cyano (isocyano) radicals or ions followed by recombination. Both processes have been rejected since the photoisomerisation (5)  $\rightarrow$  (6) did not

A dimer of azidoacetone was formed when the azide (1) was heated at 125 °C. The tentatively assigned ditetrazolopyrazine structure (15) is compatible with its i.r., n.m.r., and mass spectrometric data and elemental

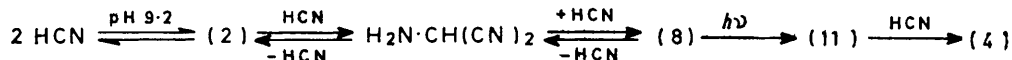

occur and silver cyanide did not transform the cyanide (5) into the isocyanide (6).

An intramolecular photorearrangement (2)  $\rightarrow$  (3) is now suggested. An initial reversible cyclisation of (2) into a zwitterionic form (12) of azirinimine (13) is facilitated by a polarisation of (2) into a zwitterionic nitrenium ion<sup>19</sup> and is followed by proton migration with ring-opening to give (2) by path *a* and (3) by path *b*. Although the unknown imine (13), calculated<sup>20</sup> to be more stable than its isomer (2), was not detected, the photoisomerisation of either (12) or (13) into (2) and (3) is supported by a comparable photoisomerisation of an azirine into both a cyanide and an isocyanide.<sup>21</sup> The absence of isomerisation of an *N*-alkylformimidoyl cyanide (5) into an isocyanide (6) can be attributed to a greater resistance toward the dissociation of a carbenium ion from a positively charged nitrogen atom.

Formimidoyl cyanide (2) is a common intermediate in the transformation of azidoacetone into adenine (4) and the sequence, proposed by Ferris and his co-workers, for the base-catalysed oligomerisation of hydrogen cyanide into adenine.<sup>1</sup> An alternative sequence for the transformation (2)  $\rightarrow$  (4) is found in the isomerisation of the cyanide (2) into the isocyanide (3)

analysis. The comparable dimer of allyl azide is a ditriazolopyrazine (16).<sup>23</sup>

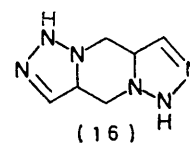
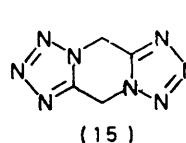
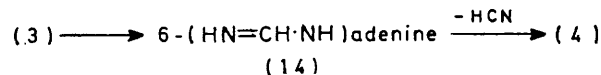

#### EXPERIMENTAL

Instruments included Perkin-Elmer grating i.r. spectrophotometers models 237B and 521, a Varian A60 n.m.r. spectrometer, a Perkin-Elmer 270 mass spectrometer, and an A.E.I. MS30 double-beam mass spectrometer.

Irradiations were carried out in a Rayonet RPR 100 photochemical chamber reactor (Southern New England Ultraviolet Co.) equipped with 16 low pressure lamps having a principal emission at 254 or 300 nm, or with a 450 W medium-pressure Hanovia lamp fitted with a Vycor filter and housed in a water-cooled quartz cell. Before irradiation under nitrogen, solutions were flushed with nitrogen (prepurified grade). Spectrograde cyclohexane was distilled from lithium aluminium hydride directly into the quartz reactor tube. Low-temperature photolysis experiments were conducted in a variable temperature i.r. cell (No. VLT-2; Beckman) which was placed either in the Rayonet reactor or adjacent to the quartz immersion well containing the 450 W Hanovia lamp. In all cases, after the starting material had been deposited as a liquid film on the

<sup>16</sup> J. P. Ferris and J. E. Kuder, *J. Amer. Chem. Soc.*, 1970, **92**, 2527.

<sup>17</sup> R. S. Becker, J. Kolc, and W. Rothman, *J. Amer. Chem. Soc.*, 1973, **95**, 1269.

<sup>18</sup> T. H. Koch and R. M. Rodchorst, *J. Amer. Chem. Soc.*, 1974, **96**, 6707; L. De Vries, *J. Org. Chem.*, 1974, **39**, 1707.

<sup>19</sup> T. Fukunaga, *J. Amer. Chem. Soc.*, 1972, **94**, 3242.

<sup>20</sup> W. Yang, R. D. Minard, and C. N. Matthews, *J.C.S. Chem. Comm.*, 1973, 435.

<sup>21</sup> W. Bauer and K. Hafner, *Angew. Chem. Internat. Edn.*, 1969, **8**, 772.

<sup>22</sup> H. Douchis, *J. Org. Chem.*, 1972, **37**, 2583; G. Hofle, *Tetrahedron Letters*, 1974, 347.

<sup>23</sup> J. C. Pezzulo and E. R. Boyko, *J. Org. Chem.*, 1973, **38**, 168.

sodium chloride cell windows, the cell was brought to 0.05 mmHg and  $-196^{\circ}\text{C}$  by stepwise evacuation and cooling with liquid nitrogen. For paper chromatography Whatman 3MM paper was used with butan-1-ol-acetic acid-water (4 : 1 : 1) (BAW), propan-1-ol-*n*-ammonium hydroxide (3 : 1) (PA), butan-1-ol-diethylene glycol-water (4 : 1 : 1) (BDW), or butan-1-ol saturated with water (BW) as developing solvent. Spots were located by u.v. irradiation at 254 nm.

G.l.c. analyses were carried out on a Varian 1800 gas chromatograph equipped with flame ionisation detectors and a Varian 20 recorder with disc integrator. Columns (Varian Aerograph) were 5 in  $\times$  0.25 in stainless steel packed with 3% GE-SE-30 on Varaport 30 (100—120 mesh) or with 5% GE-XE-60 on Chromosorb G (60—80 mesh) AW DMGS. Prior to use with silylated compounds, the columns were conditioned with Silyl-8 (Pierce Chemical Co.).

Elemental analyses were obtained from Micro-Tech Laboratories, Skokie, Illinois. Yields are based on starting material consumed.

Azidoacetonitrile, b.p.  $53^{\circ}$  at 12 mmHg, was prepared as described;<sup>24</sup> *m/e* (70 eV) 83(0.5%), 82(10), 58(1), 54(1), 53(10), 52(1), 44(0.5), 43(3), 42(1), 41(1), 40(3), 39(1), 38(1), 32(14), 30(13), 28(100), 27(80), and 26(11); *m/e* (20 eV) 83(1%), 82(18), 54(2), 53(15), 28(49), 27(100), and 26(1).

**Irradiation of Azidoacetonitrile.**—Azidoacetonitrile (2.05 g, 25 mmol) in cyclohexane (500 ml) was flushed with nitrogen for 12 h and irradiated at 254 nm in a Rayonet reactor for 24 h under nitrogen. As the azide was consumed a brown solid was precipitated and was isolated by filtration. The crude product showed *m/e* (70 eV) 135(86%), 108(85), 95(34), 85(32), 83(73), 81(80), and 57(100); the spectrum contained all the peaks found in the mass spectrum of adenine<sup>25</sup> at 70 eV, *m/e* 135(87%), 108(24), 95(15), 85(20), 83(32), 81(38), and 57(100), and at 12 eV, *m/e* 135. The brown solid was dissolved in *n*-hydrochloric acid and subjected to paper chromatography. The spot with the same  $R_F$  value as adenine was eluted by boiling *n*-hydrochloric acid and the material chromatographed in a different solvent system. This process was repeated through four solvent systems. Adenine and the product had  $R_F$  values 0.26 (BDW), 0.45 (PA), 0.15 (BW), and 0.13 (BAW). The efficiency of the conversion (1)  $\rightarrow$  (4) was estimated to be less than 1%.

The brown solid was silylated according to the procedure of Gehrke.<sup>26</sup> The silylated sample had the same g.l.c. retention time as authentic adenine silylated by the same method (relative to phenanthrene as internal standard; column temperature  $160^{\circ}\text{C}$ ).

In a similar experiment azidoacetonitrile (1.50 g) in degassed methylene chloride (12 ml) was irradiated at 300 nm for 110 h. Distillation at  $40^{\circ}\text{C}$  removed hydrogen cyanide and methylene chloride [ $\nu_{\text{max}}$  3 240 (H—C $\equiv$ ) and 2 090  $\text{cm}^{-1}$  (—C $\equiv$ N), identical with the absorptions for authentic hydrogen cyanide in methylene chloride]. The hydrogen cyanide was estimated by passing it through a solution of silver nitrate, which gave silver cyanide (329 mg, 29%) after washing with water and with acetone and drying for 24 h at  $65^{\circ}\text{C}$ . Removal of solvent and azidoacetonitrile (1.16 g, 77%) from the original product mixture left a dark brown powder (126 mg, 55%) assumed to be polymeric formimidoyl cyanide.

<sup>24</sup> K. Freudenberg, H. Eichel, and F. Leutert, *Ber.*, 1932, **65**, 1183.

<sup>25</sup> J. S. Connolly and H. Linschitz, *J. Heterocyclic Chem.*, 1972, **9**, 379.

Heating azidoacetonitrile (4.0 g, 0.05 mol) under nitrogen in a stainless steel bomb at  $125^{\circ}\text{C}$  for 62 h gave a crystalline solid covered with a finely divided black solid. After three sublimations ( $195^{\circ}$  and 0.05 mmHg) this gave 5H-, 10H-*ditetrazolo*[1,5-*a*:1',5'-*d*]pyrazine (15), which, when heated rapidly on a Kofler hot stage, sublimed at  $235^{\circ}\text{C}$  and became discoloured at  $355^{\circ}\text{C}$ ;  $\nu_{\text{max}}$  (KBr) 2 874m, 2 841m, 1 748w, 1 517w, 1 511w, 1 479s, 1 441s, 1 359s, 1 258s, 1 235m, and 1 220sh  $\text{cm}^{-1}$ ;  $\delta$  [(CD<sub>3</sub>)<sub>2</sub>SO] 6.14 (s); *m/e* (70 eV) 164 (Found: C, 29.45; H, 2.45; N, 68.15. C<sub>4</sub>H<sub>4</sub>N<sub>8</sub> requires C, 29.3; H, 2.45; N, 68.25%).

Azidoacetonitrile at  $-196^{\circ}\text{C}$  was irradiated with light from a 450 W Hanovia lamp with a Vycor filter. I.r. data were recorded after various times (see Table).

Irradiation of azidoacetonitrile (1) at  $-196^{\circ}\text{C}$  monitored by i.r. absorption

Time (min)	$\nu_{\text{max}}$ (film)/ $\text{cm}^{-1}$
0	3 003w, 2 958w, 2 257w, 2 217m, 2 183m, 2 150s, sh, 2 118s, 2 087s, 1 427m, 1 336w, 1 285s, sh, 1 265s, 1 220m, 990w, 925s, 876m, 675m
20	3 250s, 3 155s, 2 217w, 2 146s, sh, 2 123s, 2 092m, 1 605m, 1 425w, 1 379w, 1 333w, 1 264s, 1 220m, 995w, 929m, 905m, 877m, 822m, 803m
80	3 250s, 3 135s, 2 232w, 2 146w, 2 101s, 1 618w, sh, 1 605m, 1 383w, 1 258m, 987w, 905m, 826s
540	3 250s, sh, 3 135s, 2 232w, 2 146w, 2 101s, 2 058w, 1 618s, 1 258w, 985w, 948w, 830s

***N*-Alkylformimidoyl Cyanides.**—The preparation of *N*-alkylformimidoyl cyanides (5) is described elsewhere.<sup>3,27</sup> Each cyanide (14 mmol) in methylene chloride (10 ml), previously degassed with a stream of nitrogen, was irradiated at 300 nm for 90 (5a and b) or 250 h (5c). The reaction was monitored by g.l.c. with *n*-decane as internal standard, helium as carrier gas, column at  $75^{\circ}\text{C}$ , injection port at  $120^{\circ}\text{C}$ , detector at  $180^{\circ}\text{C}$ . Recoveries of imidoyl cyanide were 54 (5a), 83 (5b), and 74% (5c), with corresponding retention times (min) 16 (*syn*) and 4.8 (*anti*) (5a), 19 (*syn*) and 6.6 (*anti*) (5b), and 31 (*syn*) (5c). The yields (based on initial quantity of cyanide) of alkyl isocyanide<sup>28</sup> were 2 (7a), 3 (7b), and 3% (7c), with retention times 2.3, 2.4, and 2.6 min.

Distillation of each product mixture gave hydrogen cyanide with solvent. Absorption was identical with that obtained for an authentic sample:<sup>29</sup>  $\nu_{\text{max}}$  (CH<sub>2</sub>Cl<sub>2</sub>) 3 240 (CH), 2 091 (C $\equiv$ N), 1 455 (CH), and 772  $\text{cm}^{-1}$  (CH). I.r. data for hydrogen cyanide in acetonitrile, chloroform, carbon tetrachloride, cyclohexane, and carbon disulphide were also obtained. Strong CH stretching absorption was found at  $3 250 \pm 10 \text{ cm}^{-1}$  except for the solution in acetonitrile ( $3 155 \text{ cm}^{-1}$ ). In all solvents weak C $\equiv$ N stretching absorption was found at  $2 090 \pm 1 \text{ cm}^{-1}$ . In acetonitrile, cyclohexane, and carbon disulphide CH bending absorption was not observed, and was broad and weak in methylene chloride, chloroform (1 450  $\text{cm}^{-1}$ ), and carbon tetrachloride (1 432  $\text{cm}^{-1}$ ). CH Rocking absorption was medium and broad in acetonitrile, methylene chloride, and chloroform at  $772 \pm 10 \text{ cm}^{-1}$ , and medium to strong in carbon tetrachloride, cyclohexane, and carbon disulphide at  $722 \pm 10 \text{ cm}^{-1}$ .

<sup>26</sup> G. W. Gehrke and C. D. Ruyle, *J. Chromatog.*, 1968, **33**, 473.

<sup>27</sup> J. H. Boyer and J. Kooi, 'Iminofomyl Cyanides and Isocyanides,' Abstracts of Papers ORGN 64, American Chemical Society National Annual Meeting, Atlantic City, September 1974.

<sup>28</sup> I. Ugi and R. Meyr, *Chem. Ber.*, 1960, **93**, 239; H. L. Jackson and B. C. McKusick, *Org. Synth.*, Coll. Vol. IV, 1963, p. 438.

<sup>29</sup> K. Ziegler, *Org. Synth.*, Coll. Vol. I, 1941, p. 314.

Methylene chloride and other low-boiling materials were evaporated from the pot residue at room temperature by slowly decreasing the pressure to 20 (5a), 10 (5b), or 5 mmHg (5c). The material removed by evaporation was collected in a receiver cooled to *ca.*  $-40^{\circ}\text{C}$ . At room temperature it was treated with dilute aqueous sodium hydrogen sulphite to remove unchanged *N*-alkylformimidoyl cyanide (5), and with dilute aqueous sodium carbonate to remove hydrogen cyanide. After drying ( $\text{CaCl}_2$ ), methylene chloride was removed by distillation at  $40^{\circ}\text{C}$  and the residue was evaporated at room temperature and 2 mmHg. Each isocyanide (7) with methylene chloride was collected in a receiver cooled to  $-40^{\circ}\text{C}$ . Ethyl

<sup>30</sup> J. Casanova, jun., N. D. Werner, and R. E. Schuster, *J. Org. Chem.*, 1966, **31**, 3473.

<sup>31</sup> D. Kuntz, jun., P. von R. Schleyer, and A. Allerhand, *J. Chem. Phys.*, 1961, **35**, 1533.

isocyanide (7a) <sup>30</sup> showed  $\delta$  ( $\text{CH}_2\text{Cl}_2$ ) 1.32 (3H, tt,  $J_{\text{HH}}$  7,  $J_{\text{NH}}$  3 Hz,  $\text{CH}_3$ ) and 3.40 (2H, tq,  $J_{\text{HH}}$  7,  $J_{\text{NH}}$  2 Hz,  $\text{CH}_2$ );  $\nu_{\text{max.}}$  ( $\text{CH}_2\text{Cl}_2$ ) 2 980 (CH) and 2 145  $\text{cm}^{-1}$  ( $-\overset{+}{\text{N}}\equiv\bar{\text{C}}$ ). Isopropyl isocyanide (7b) <sup>30,31</sup> showed  $\delta$  ( $\text{CH}_2\text{Cl}_2$ ) 1.36 (6H, td,  $J_{\text{HH}}$  7,  $J_{\text{NH}}$  2 Hz,  $\text{CH}_2$ ) and 3.74 (1 H, tsept,  $J_{\text{HH}}$  7,  $J_{\text{NH}}$  2 Hz, CH);  $\nu_{\text{max.}}$  ( $\text{CH}_2\text{Cl}_2$ ) 2 970 (CH) and 2 145  $\text{cm}^{-1}$  ( $-\overset{+}{\text{N}}\equiv\bar{\text{C}}$ ). *t*-Butyl isocyanide <sup>30,31</sup> (7c) showed  $\delta$  ( $\text{CH}_2\text{Cl}_2$ ) 1.44 (9 H, t,  $J_{\text{NH}}$  2 Hz,  $\text{CH}_3$ );  $\nu_{\text{max.}}$  ( $\text{CH}_2\text{Cl}_2$ ) 2 940 (CH) and 2 140  $\text{cm}^{-1}$  ( $-\overset{+}{\text{N}}\equiv\bar{\text{C}}$ ).

Each *N*-alkylformimidoyl cyanide (5) was also irradiated at  $-196^{\circ}\text{C}$  with light from a 450 Hanovia lamp with a Vycor filter. The corresponding alkyl cyanide (7) was detected in each experiment.

Financial support was received from N.S.F. and N.A.S.A.

[5/264 Received, 10th February, 1975]